



Features

- Carbon element
- 10-30 mm travel
- Center detent option
- Single or dual gang
- RoHS compliant*

Applications

- Audio/TV sets
- Car radio
- Amplifiers/mixers/drum machines/synthesizers
- PCs/monitors
- Appliances

PDV Series - Open Frame Slide Potentiometer

Electrical Characteristics

TaperLinear, audio
 Standard Resistance Range
1 K ohms to 1 M ohms
 Standard Resistance Tolerance±20 %
 Residual Resistance
100 ohms or ±5 % max.

Environmental Characteristics

Operating Temperature ...-10 °C to +50 °C
 Power Rating
 Linear0.1 watt
 Audio0.05 watt
 Maximum Operating Voltage - Linear
 10 mm Travel100 VAC
 15 mm Travel100 VAC
 20 mm Travel200 VAC
 30 mm Travel200 VAC
 Maximum Operating Voltage - Audio
 10 mm Travel50 VAC
 15 mm Travel50 VAC
 20 mm Travel150 VAC
 30 mm Travel150 VAC
 Sliding Noise47 mV max.

Mechanical Characteristics

Operating Force20 to 300 g-cm
 Detent Torque50 to 400 g-cm
 Lever Stop Strength3 kg-cm min.
 Sliding Life10,000 cycles
 Standard Stroke Length
10, 15, 20, 30 mm
 Soldering Condition
 Wave260 °C for 3 sec. max.
 ManualNot recommended

How To Order

PDV10 - 2 1 P - 102 A

Model _____

Length of Travel _____

- 10 = 10 mm
- 15 = 15 mm
- 20 = 20 mm
- 30 = 30 mm

Detent Option _____

- 2 = No Detent
- 3 = Center Detent

Number of Gangs _____

- 1 = Single Gang
- 2 = Dual Gang

Mounting Type _____
 (refer to drawings)

- A = Vertical Pins
- D = Vertical Pins
- P = Vertical Pins
- H = Horizontal Pins
- M = Horizontal Pins
- B = Horizontal Pins

Resistance Code (See Table) _____

Resistance Taper _____

- A = Audio Taper
- B = Linear Taper

Other styles available.

Product Dimensions

PDVxx-x1D

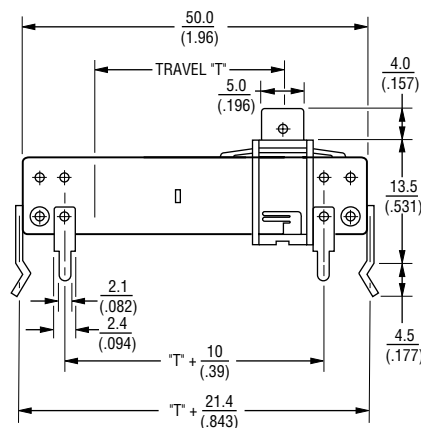

PDVxx-x2D

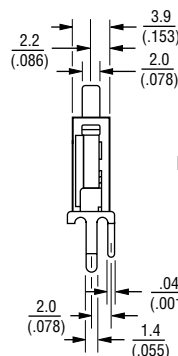
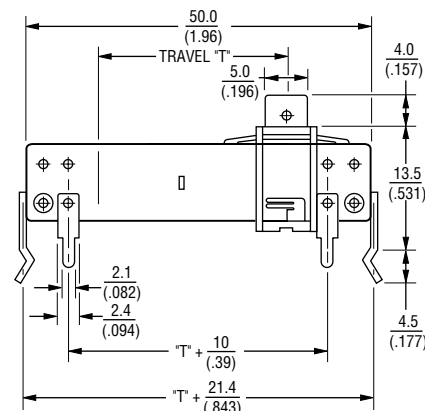

DIMENSIONS ARE: $\frac{\text{MM}}{\text{(INCHES)}}$

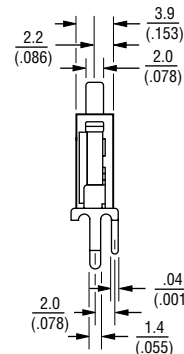

RECOMMENDED PCB LAYOUT

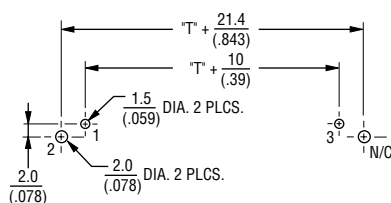

RECOMMENDED PCB LAYOUT

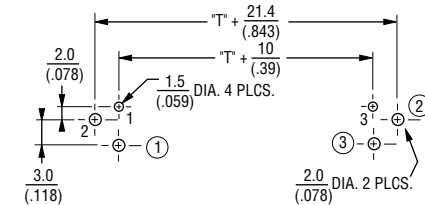

Standard Resistance Table

Resistance (Ohms)	Resistance Code
1,000	102
2,000	202
5,000	502
10,000	103
20,000	203
50,000	503
100,000	104
200,000	204
500,000	504
1,000,000	105

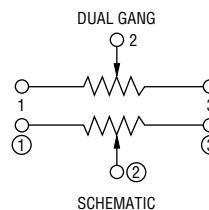
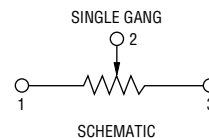

*RoHS Directive 2002/95/EC Jan 27 2003 including Annex. Specifications are subject to change without notice. Customers should verify actual device performance in their specific applications.

PDV Series - Open Frame Slide Potentiometer

BOURNS®

Product Dimensions

PDVxx-x1P

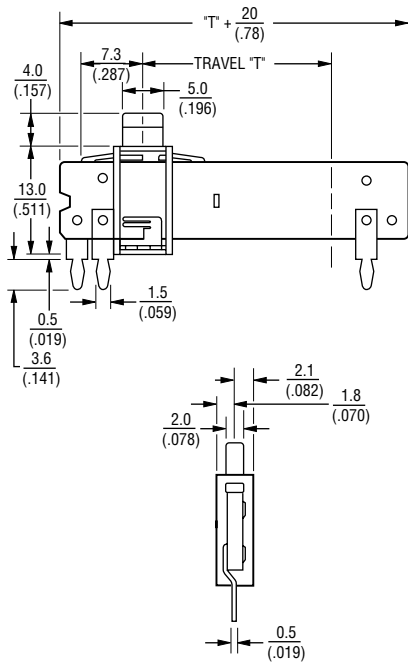

RECOMMENDED PCB LAYOUT

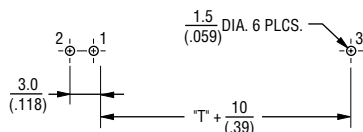

SINGLE GANG

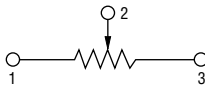

SCHEMATIC

PDVxx-x2P

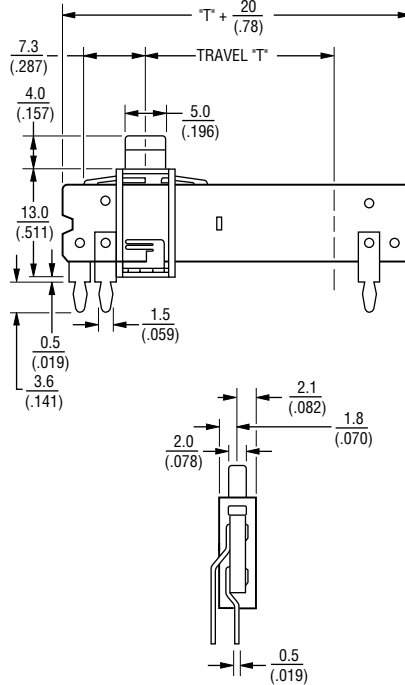

RECOMMENDED PCB LAYOUT

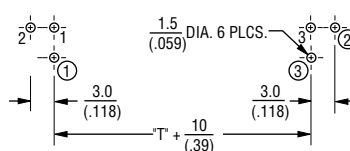

DUAL GANG

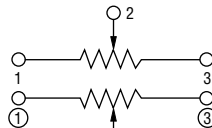

SCHEMATIC

PDVxx-x1H

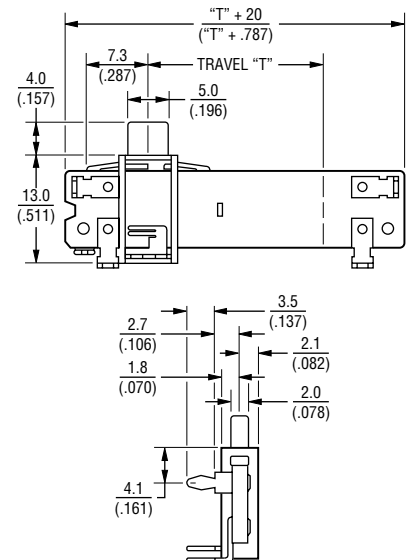

RECOMMENDED PCB LAYOUT

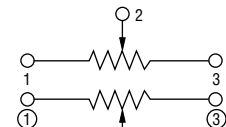
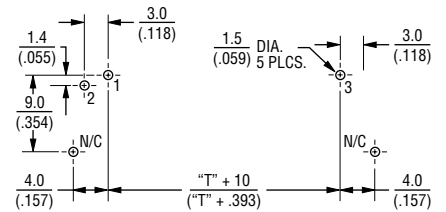

SCHEMATIC

Derating Curve

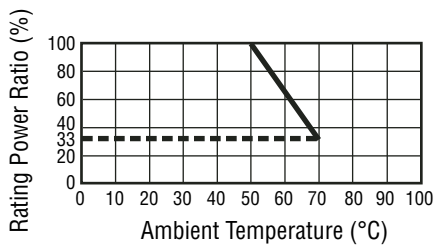

DIMENSIONS ARE: $\frac{\text{MM}}{\text{(INCHES)}}$

Specifications are subject to change without notice. Customers should verify actual device performance in their specific applications.

PDV Series - Open Frame Slide Potentiometer

BOURNS®

Product Dimensions

PDVxx-x2H

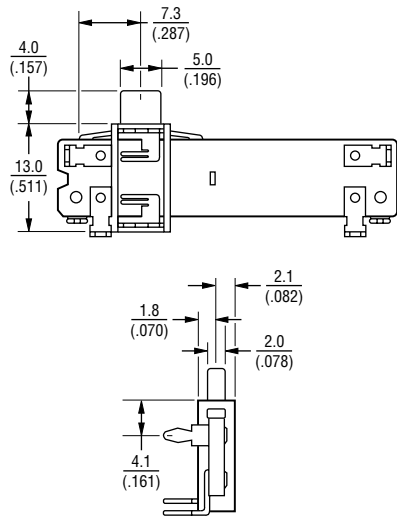

PDVxx-x1M

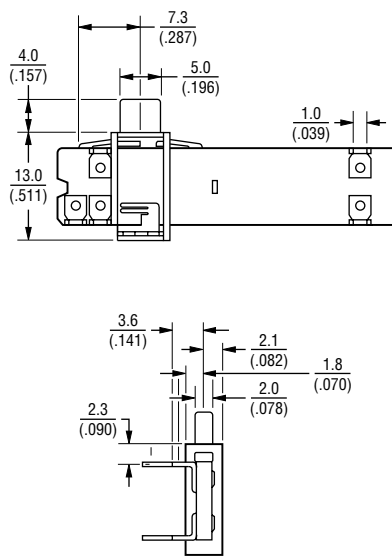

PDVxx-x2M

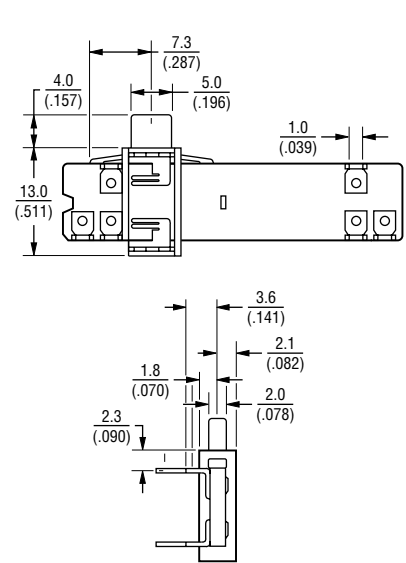

RECOMMENDED PCB LAYOUT

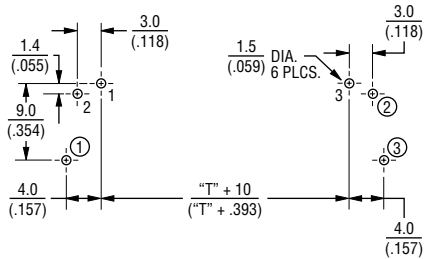

RECOMMENDED PCB LAYOUT

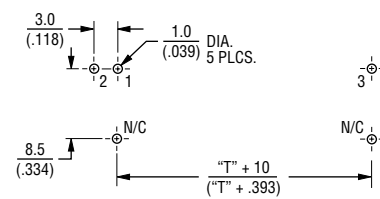

RECOMMENDED PCB LAYOUT

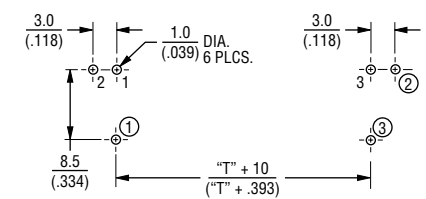

DIMENSIONS ARE: $\frac{\text{MM}}{\text{(INCHES)}}$

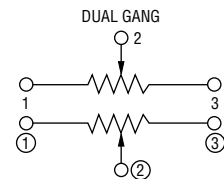
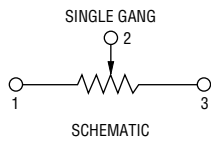

PDV Series - Open Frame Slide Potentiometer

BOURNS®

Product Dimensions

PDVxx-x2A

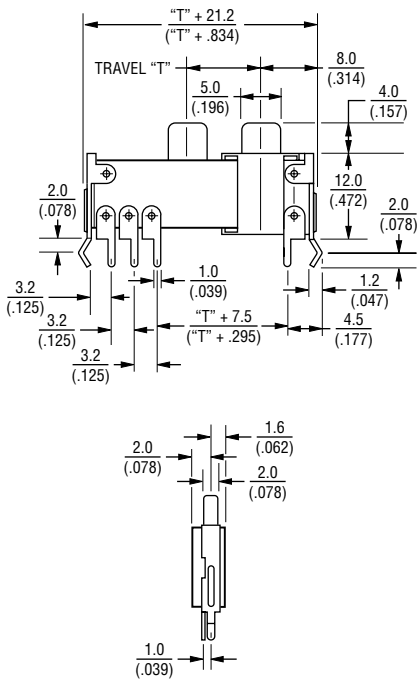

RECOMMENDED PCB LAYOUT

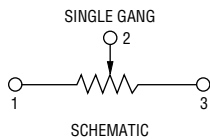
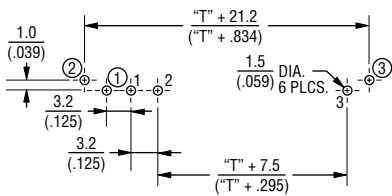

PDVxx-x2B

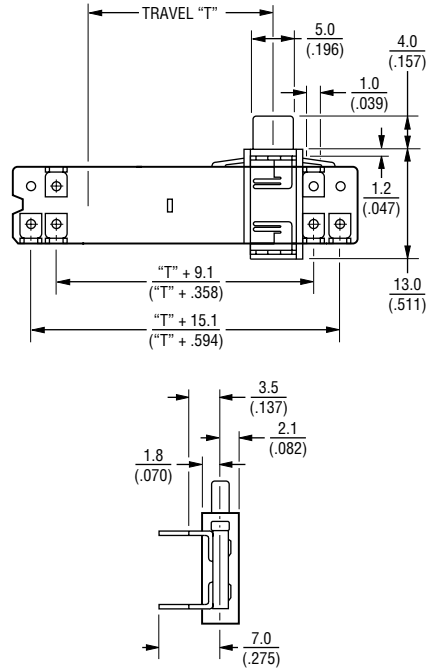

RECOMMENDED PCB LAYOUT

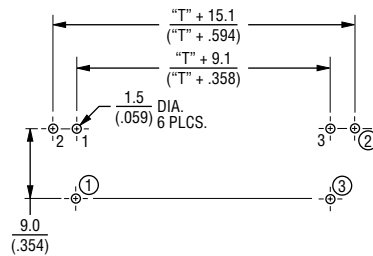

DIMENSIONS ARE: $\frac{\text{MM}}{\text{(INCHES)}}$

PDVxx-x2C

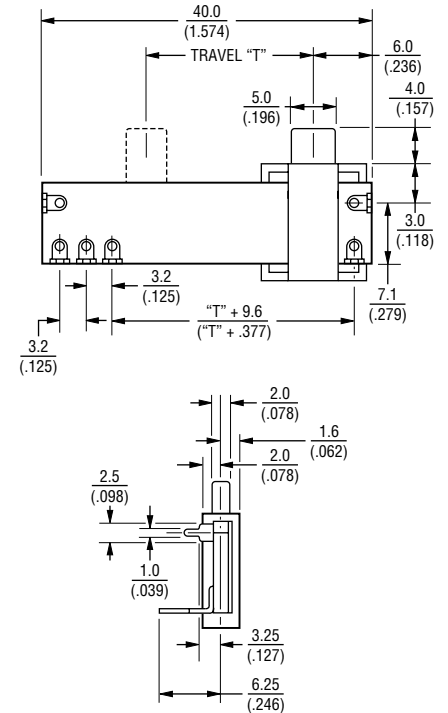

RECOMMENDED PCB LAYOUT

